



“Ubiquitous power” for future power systems with low environmental loads

Research Objectives

1. Establish a society with low environmental loads and robustness for disasters by using renewable distributed type generators and energy storage devices
2. Development of transmission and distribution technologies enables introduction of more and more renewable distributed type generators by using power electronics and superconductivity technologies

Abstract of Research Projects

1. Control schemes and protection schemes of the bipolar-type dc distribution systems have already been developed, inductive contactless power transfer outlet and circuit configuration of ac/dc power converter to connect with ac grid are current research scopes.
2. Virtual synchronous generator (VSG) for control of inverters of distributed generations is intensively under study. Effectiveness of the control scheme was verified by computer simulations and experiments, and various applications of VSGs in distributed generation systems are under study. A high efficiency ac/dc power converter using a soft switching technique, GaN power switching devices are under developing. A bi-directional power flow and high efficiency battery charger for electric vehicles is also under developing.
3. Control schemes of a modular multi-level matrix converter for high power frequency converters are under developing. Voltage balancing control between capacitors has been developed and low harmonic distortion has been achieved.
4. Developing variable speed type gas-engine generation system for higher electrical efficiency and compensation of power fluctuation from renewable generations by using a doubly fed induction generator (DFIG).

Research Projects

1. Future power delivery systems such as DC distribution system and microgrids including many distributed generations with low environmental loads
2. Power conditioning system with a power system stabilization function and high efficiency for distributed generations and energy storages
3. Direct frequency converter by a matrix converter
4. Variable speed type gas engine generators, a wind turbine generation system for large off-shore wind farms, an islanded network-type photovoltaic generation system are under studying



10 kW photovoltaic experimental generation system

Tsuyoshi Funaki, Professor

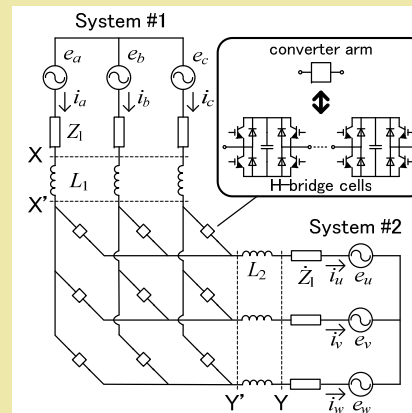

Modular Multi-level Matrix Converter